



ELEVATOR CAB
RENOVATIONS™

+



ELEVATOR
INTERIORS
& FIXTURES

FRAMED CEILING

MODEL:
TREMBLANT
BIG WHITE
MARBLE MOUNTAIN

INSTALLATION INSTRUCTIONS



TOOLS REQUIRED

- Measuring Tape
- Drill
- Ladder
- 3” Paint Brush and latex paint for painting the canopy (If required)

SECTION 1: UNPACKING

- 1.1. When your new Framed Ceiling arrives, transport it near to the cab you will be renovating and organize the crates so that they will be easily accessible.

The crates contents are itemized on its surface.

- 1.2. Carefully un-crate the ceiling package, making sure that none of the components are damaged.
- 1.3. Check the colours, features, and dimensions of the components against your order before you begin removing the existing elevator interior.

If you have any questions at this point, contact ECR before going ahead with any part of the installation.

For technical support on the Framed Ceiling installation, please contact us at:

Elevator Cab Renovations
Office: (613) 745-4870
Toll Free: 1-877-745-4870
ecr@elevatorcabs.ca

Office Hours : 6:30 AM to 3:30 PM Eastern Standard Time

SECTION 2: PREPARE FOR THE CEILING INSTALLATION

- 2.1. Unless specified otherwise, your new Framed Ceiling will be inset from the shell walls by 2" on all sides. Please consult drawings accompanying ceiling.
- 2.2. Prepare canopy surface to accept new Framed Ceiling by completing one of the following options
 - a) Sand, clean & re-paint the perimeter of the canopy with a desired color. Black or white are typical for this type of application
 - b) If the canopy is in good condition, a simple cleaning may be all that is required.



Note: It is suggested that for both options a or b, a minimum of 6" of the perimeter of the canopy should be addressed by the process chosen.

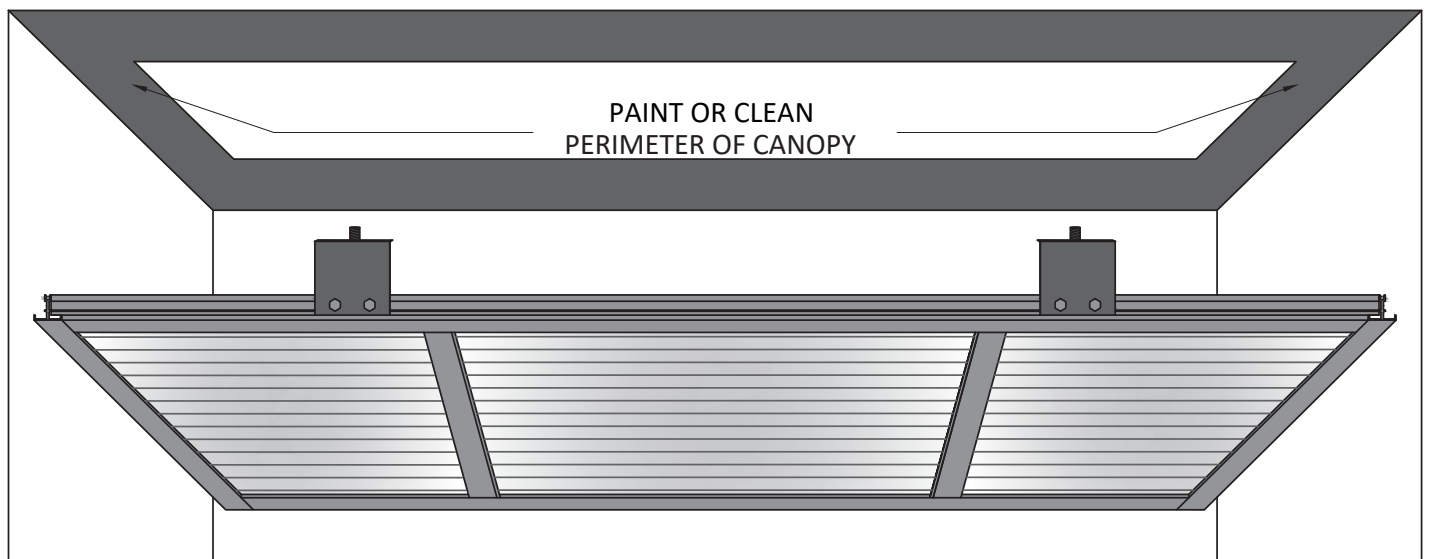

Dia. 1
Framed ceiling preparations.

SECTION 3: INSTALL THE CEILING FRAME

- 3.1. Unless requested your framed ceiling will be shipped assembled with panels in place. Light kits and support brackets are packed separately to be installed when ready.
- 3.2. The “T” frame comes with predrilled holes to attach the support brackets. The brackets can be attached to the frame using the 1/4 - 20 x 3/4 bolts provided (Dia. 2).

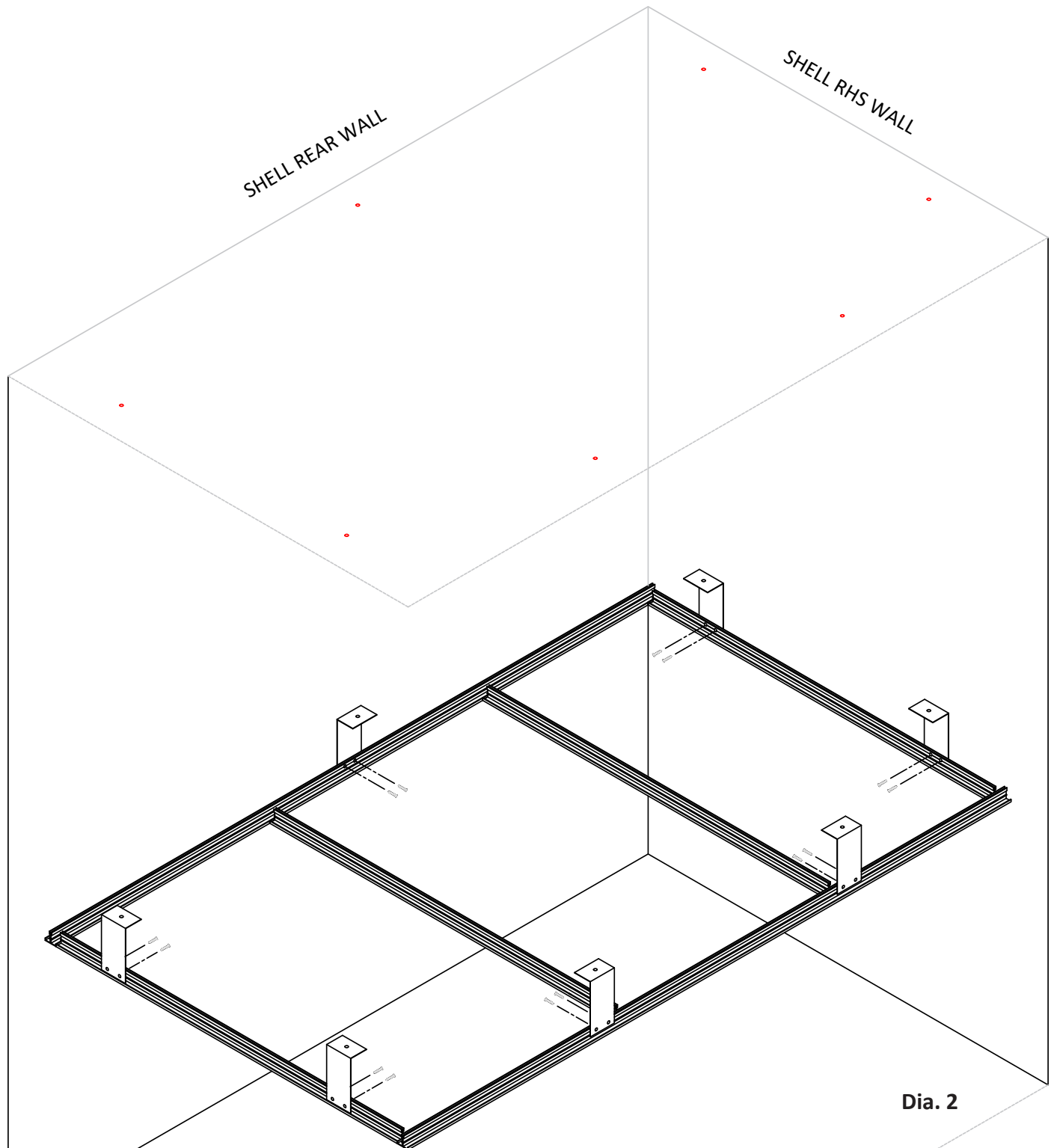

SECTION 3: INSTALL THE CEILING FRAME

- 3.3. Your ceiling includes a mounting template. This will be used to transfer hole locations from the Framed Ceiling brackets to the canopy of the cab. Determine safe locations on the car top where ceiling brackets can be installed so that fasteners are not obstructed by ribs, car top equipment, etc.
- 3.4. Place the template on top of the ceiling brackets and align it with the edge of the ceiling support frame. Once positioned, mark the mounting holes on the template and drill them out to at least 1/8" (Dia. 3).

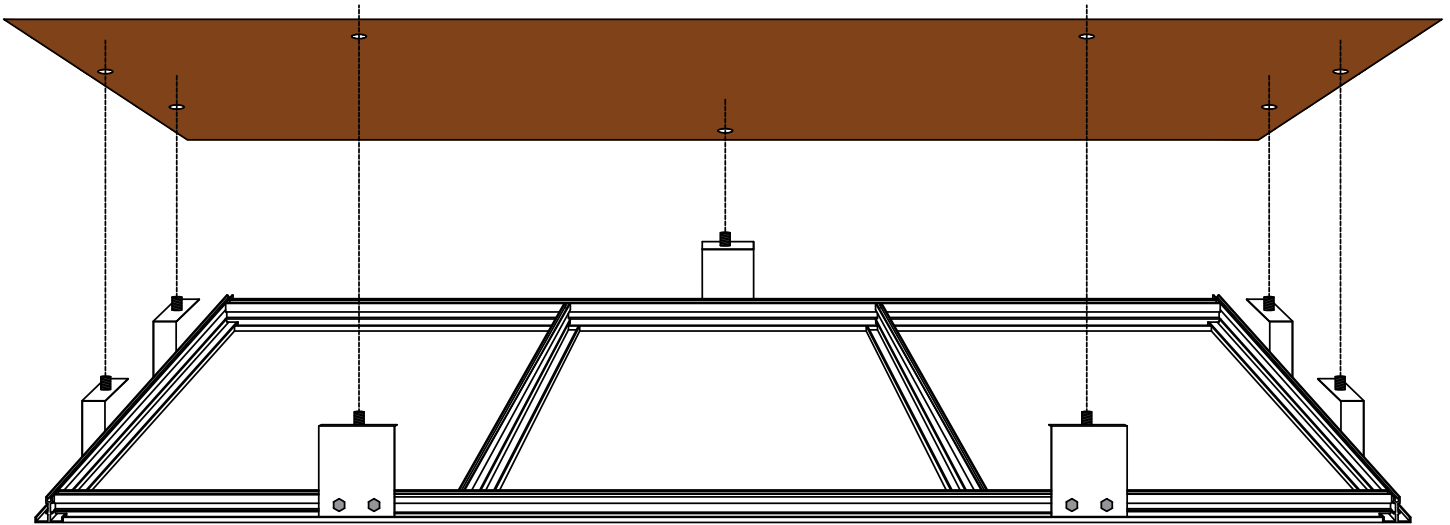

Dia. 3

Framed Ceiling with mounting template.

- 3.5. Position the template against the canopy of the cab in the desired location (typically centered side to side - verify drawings accompanying ceiling) and temporarily secure into place with screws or tape. Copy the mounting holes to the canopy by marking through the template holes. Remove the template from the canopy.
- 3.6. Before drilling in the canopy, check the top of the car for any obstructions (i.e. ducts, cable, conduit etc). Progressively drill holes up to 1/2" diameter in the canopy.



Protect any exposed wall finishes prior to raising the framed ceiling into position.

- 3.7. Remove the panels and center the frame onto the canopy to locate the attachment holes.



Note: Be sure to retain all the panel safety clips for re-installation if applicable.

SECTION 3: INSTALL THE CEILING FRAME (CONTINUED)

- 3.8. Attach the ceiling frame to the canopy using the 1/4-20 x 3" bolts provided (Dia. 4). Trim any excess bolts protruding from the canopy. Loctite can be applied to the nut/bolt assembly (Loctite is not included).



Note: Before drilling through the canopy, ensure that there are no encumbrances. If required, the brackets can be moved and re-installed to suit the site conditions.

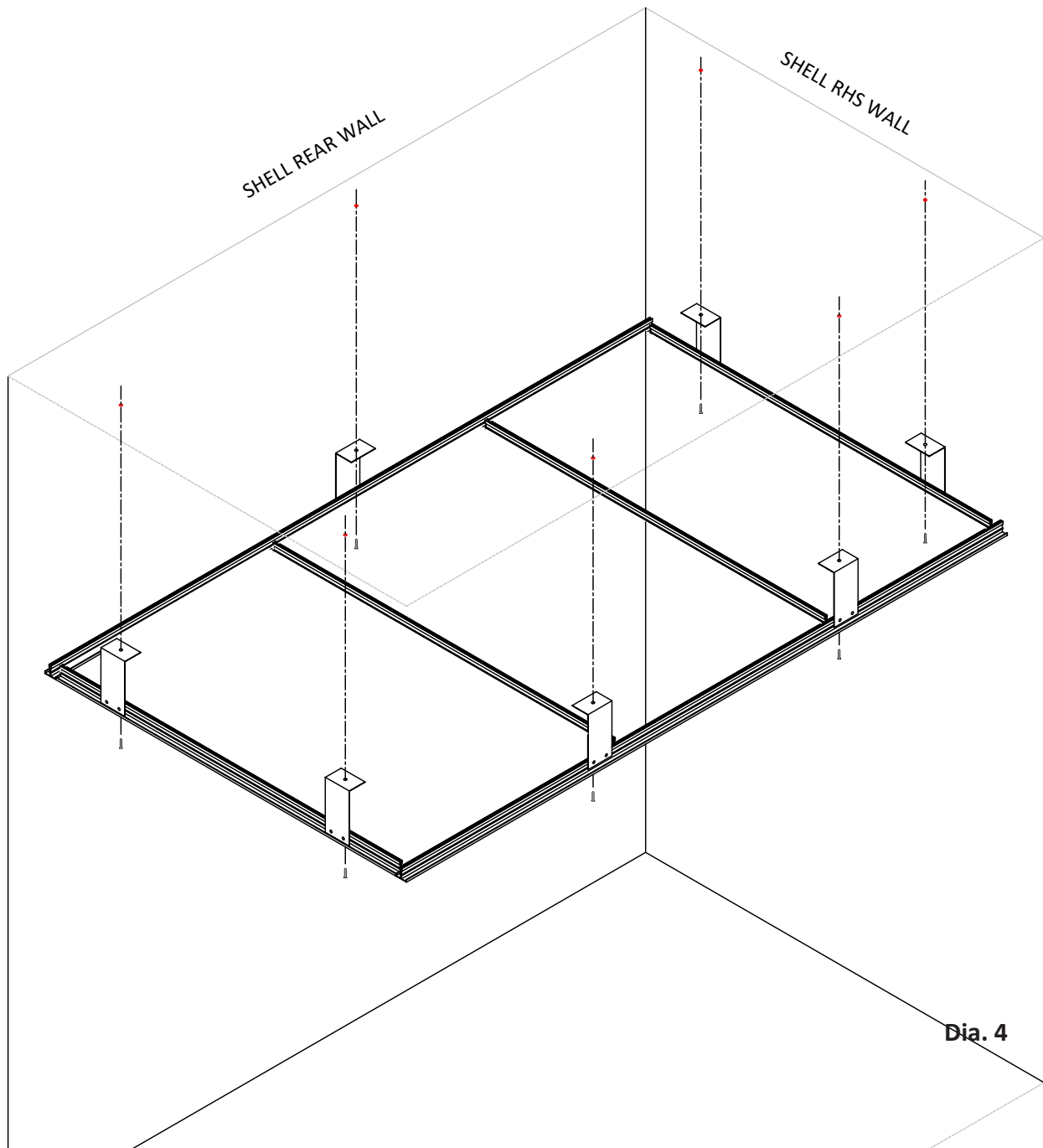

- 3.9. Install the pre-cut aluminum egg crate or polycarbonate panels into the openings in the ceiling frame. These pieces are cut to fit snugly in the frame and may need to be pulled down to sit flat on the frame.

SECTION 4: INSTALL LED LIGHTING

- 4.1. A utility box has been provided to mount to the top of a car. Connectors have also been provided for this purpose (Dia. 5). If possible, mount the utility box close to the rear of the shell on the left or right hand side to meet the lead chosen in the lighting wiring.

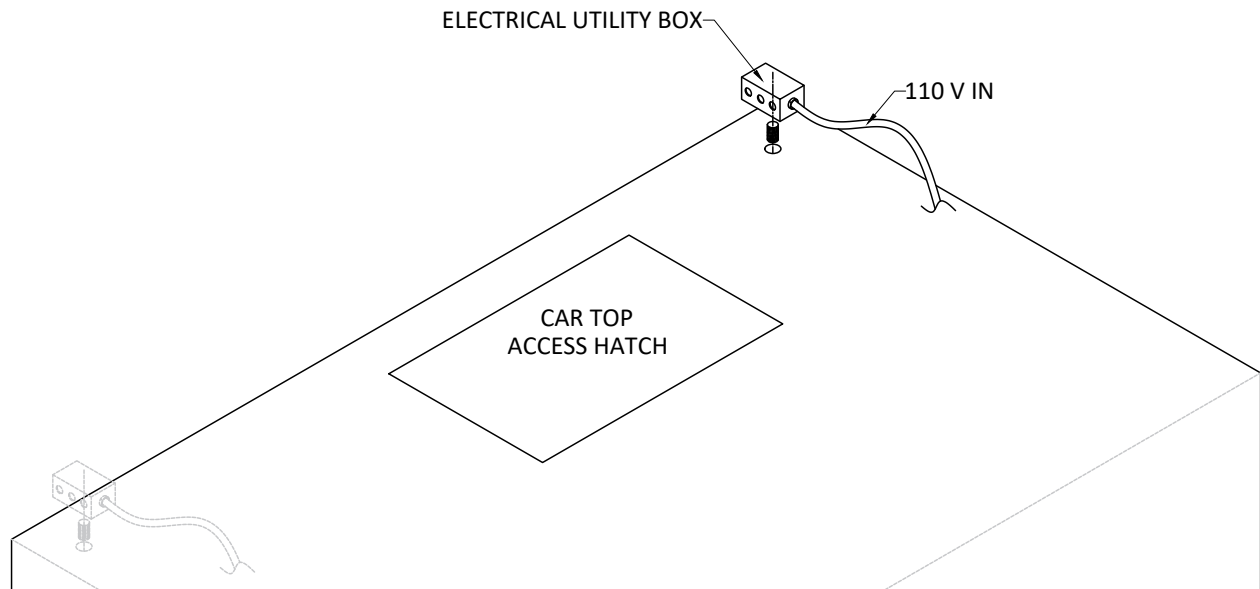

Dia. 5
Electrical box on canopy



Note: For ceilings using polycarbonate lenses, it is important to install the lighting as close to the canopy as possible. The fluted lenses can create subtle shadow lines if the lighting is installed too close to the lenses.

- 4.2. The LED strip lights can be disassembled and mounted to the frame brackets as shown in Dia. 6.
- 4.3. With the strip lights in place, they can be wired to each other with the wire connectors provided (Dia. 6).

SECTION 4: INSTALL LED LIGHTING (CONTINUED)

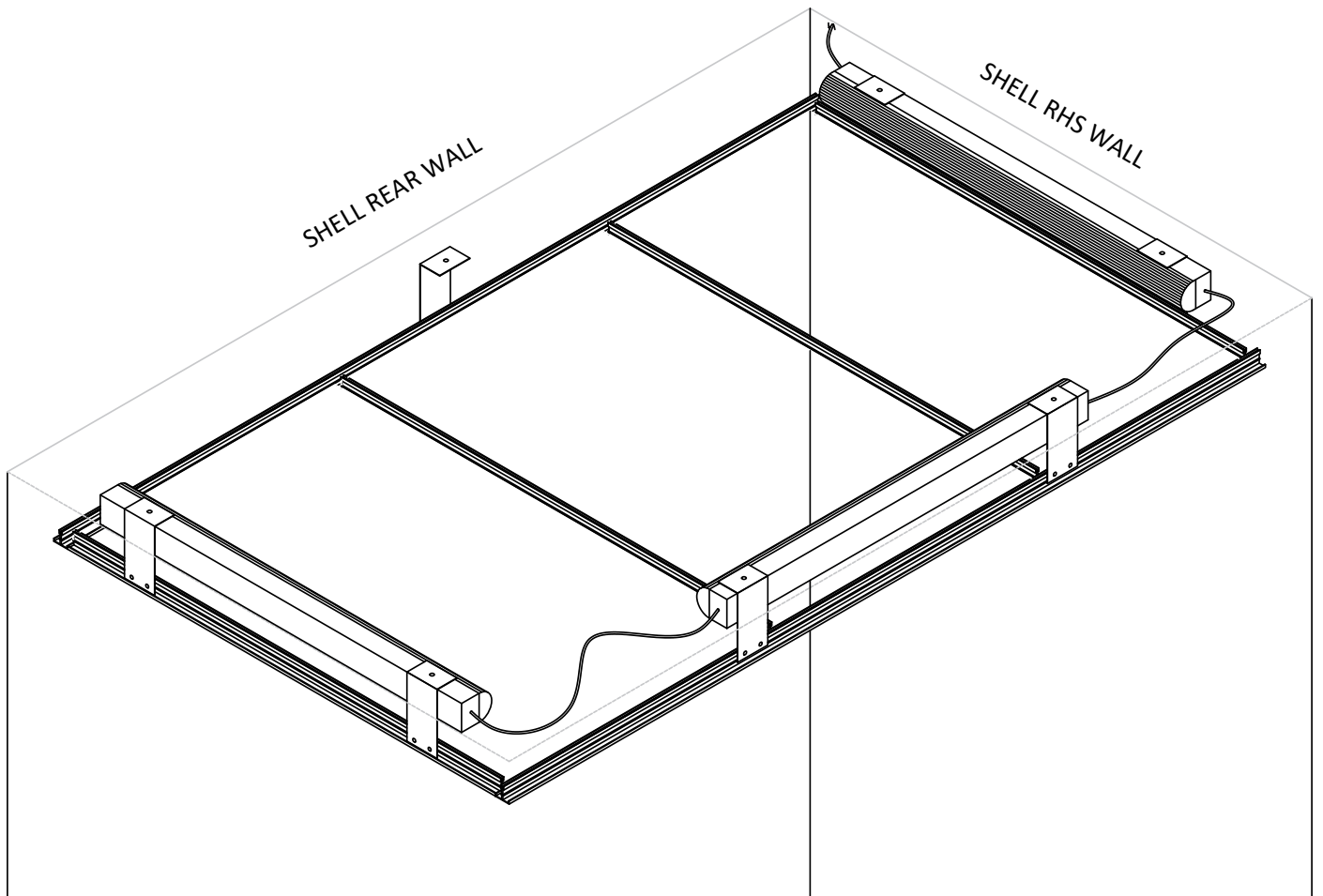

Dia. 5

GLOSSARY

Canopy:

The roof of the cab.

The top structural component of the shell.

The canopy houses the emergency hatch.

The canopy may have various electrical and mechanical components attached to its surfaces, both interior and exterior.

“T” Frame:

Extruded aluminum ceiling frame shaped in a “T”.

Ceiling Brackets:

Ceiling brackets are “L-shaped” constructed of 1/16” thick steel.

Brackets are manufactured with mounting holes for 1/4-20 bolts for fast and easy installation.

For technical support on the Framed Ceiling installation, please contact us at:

Elevator Cab Renovations

Office: (613) 745-4870

Toll Free: 1-877-745-4870

ecr@elevatorcabs.ca

Office Hours : 6:30 AM to 3:30 PM Eastern Standard Time