



MAD MATISSE FLEX WIRING DIAGRAM

DRAWING: DC00001

Issue Date
2024-03-11



Revision History

Rev 00	Description: Initial Release					
	Issue Date: 2024-03-11	Prepared by: Prabdeep Gahlla	Peer Review by: Deepak Rai	Approved by: Andrey Palcikovs		

Revision Log

Rev	Section / Paragraph	Page	Description
00	-	-	Initial Issue

DISCLAIMER

Mad Elevator Inc. prepared this document as a work of authorship. This document has been prepared solely for the benefit of the Client and may not be used or relied upon in whole or in part by any other person or entity without Client permission or without Mad Elevator Inc permission if required by the Contract between Client and Mad Elevator Inc. Inc. Neither Mad Elevator Inc., their client nor any person acting on behalf of them: (a) makes any warranty or representation whatsoever, express or implied, or assumes any legal liability of responsibility for any third party's use, or the results of such use, with respect to (i) the use of any information, apparatus, method, process, or similar item disclosed in this document including the merchantability or fitness for any particular purpose of any information contained in this document or the respective works or services supplied or performed or (ii) that such use does not infringe on or interfere with privately owned rights, including any party's intellectual property; or (b) assumes responsibility for any damages or other liability whatsoever (including any consequential damages resulting from a third party's selection or use of this document or any information, apparatus, method, process, or similar item disclosed).

Copyright © Mad Elevator Inc. 2024. All rights reserved.



Contents

1 MATISSE FLEX - DIGITAL SIGNAGE - MAIN COP4
2 MATISSE FLEX - DIGITAL SIGNAGE + PI (CAN PROTOCOL) - MAIN COP (NO VMS)5
3 MATISSE FLEX – DIGITAL SIGNAGE + PI (LINE/FLOOR, BINARY, KONE, SEC, QL, HX) – MAIN COP (NO VMS)6
4 MATISSE FLEX PI - DIGITAL SIGNAGE + PI (LINE/FLOOR, BINARY) - MAIN COP (NO VMS) -DEUM DRIVER IN MACHINE ROOM7
5 MATISSE FLEX - DIGITAL SIGNAGE + PI (CAN PROTOCOL) + VMS – MAIN8
6 MATISSE FLEX – DIGITAL SIGNAGE + PI (LINE/FLOOR, BINARY, KONE, SEC, QL, HX) + VMS – MAIN COP9
7 MATISSE FLEX PI - DIGITAL SIGNAGE + PI (LINE/FLOOR, BINARY) + VMS - MAIN COP – DEUM DRIVER IN MACHINE ROOM 10
8 MATISSE FLEX PI / DIGITAL SIGNAGE AUX COP ELECTRICAL WIRING DIAGRAM 11



1 MATISSE FLEX - DIGITAL SIGNAGE - MAIN COP

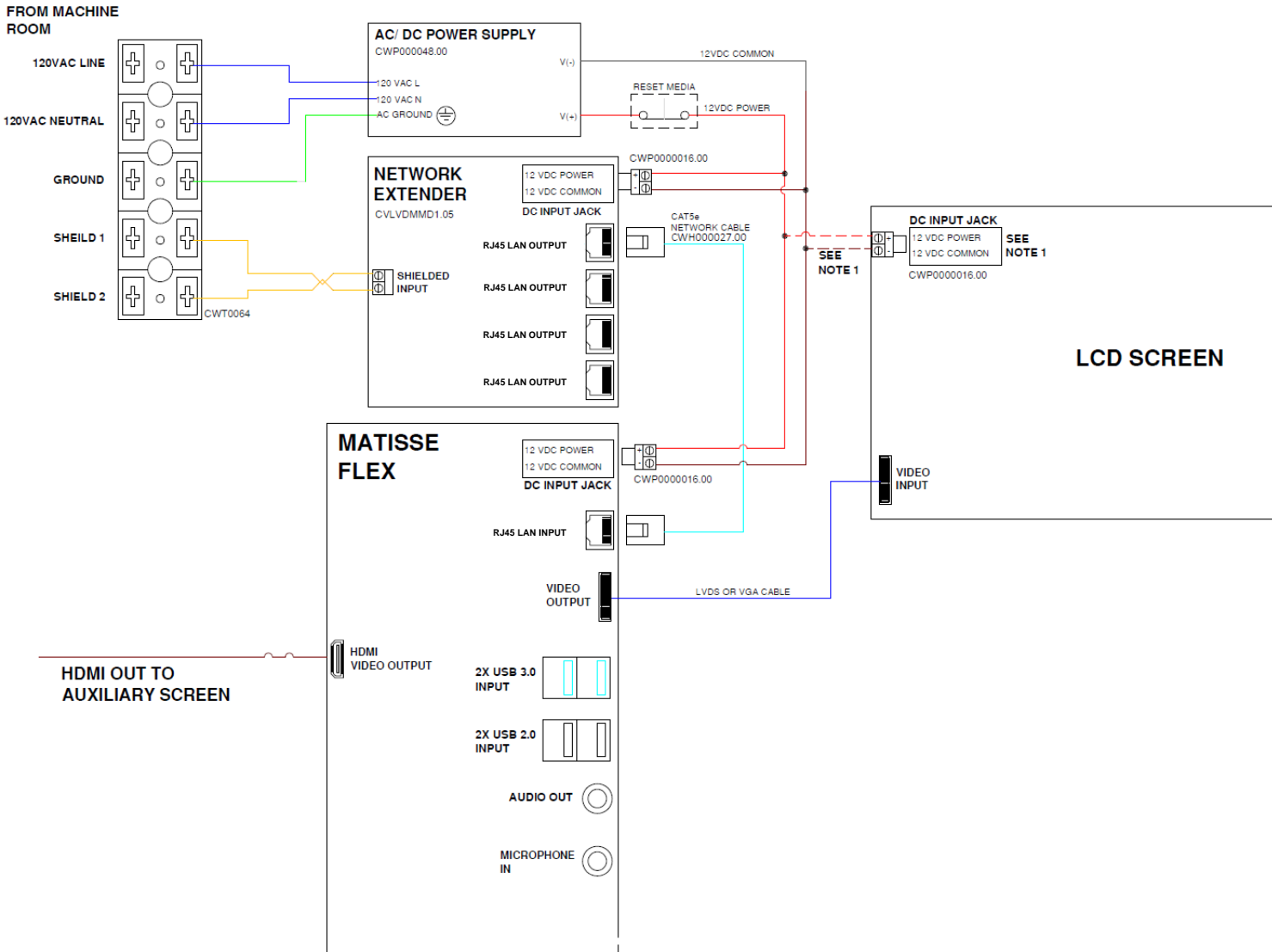

Notes:	
NOTE 1: WHEN CONNECTING THE LCD SCREEN TO MATISSEE FLEX VIA VGA CONNECT THE 12V POWER TO THE LCD POWER INPUT USING THE POWER PLUG CWP000016.00	
Voltage: 120 VAC	Signal Format:
Controller:	Code Year:
Drawing Name: Matisse Flex Digital Signage With LCD Screen MAIN COP Electrical Wiring Diagram	
Rev: 1	Qty: 1



2 MATISSE FLEX - DIGITAL SIGNAGE + PI (CAN PROTOCOL) - MAIN COP (NO VMS)

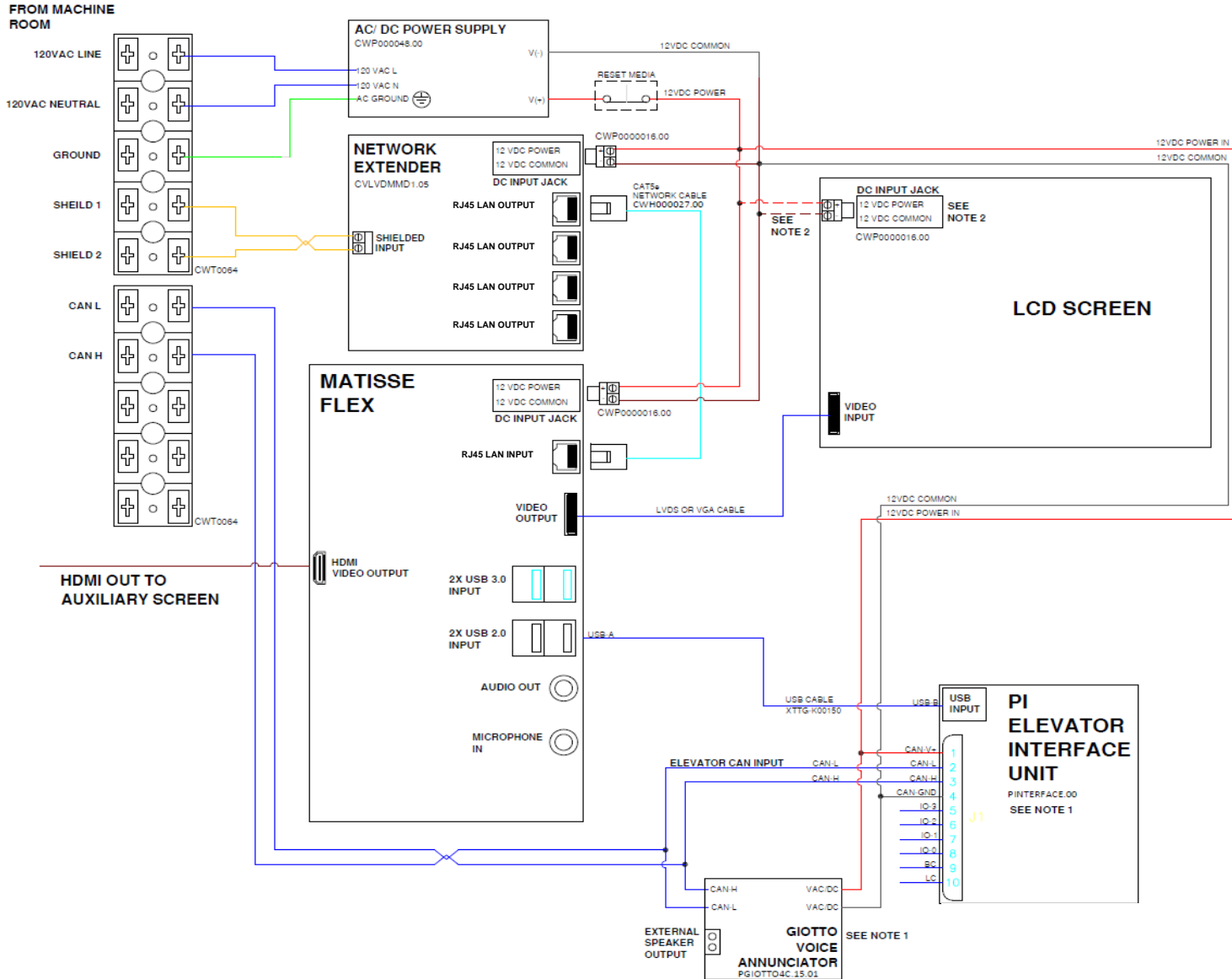

Notes:

NOTE 1: FOR ELEVATOR WITH CAN COMMUNICATION CONNECT ONLY THE EIU (PINTERFACE.00) WITH USB CABLE TO THE MATISSE FLEX. CAN H AND CAN L SIGNALS FROM THE ELEVATOR CONTROLLER ARE CONNECTED BOTH TO THE EIU AND THE VOICE ANNUNCIATOR (PGIOTTO4C.15.01).

NOTE 2: WHEN CONNECTING THE LCD SCREEN TO MATISSEFLEX VIA VGA CONNECT THE 12V POWER TO THE LCD POWER INPUT USING THE POWER PLUG CWP0000016.00

Voltage: 120 VAC	Signal Format:
Controller:	Code Year:
Drawing Name: Matisse Flex PI/Digital Signage Using CAN With LCD Screen MAIN COP Electrical Wiring Diagram	
Rev: 1	Qty: 1



3 MATISSE FLEX – DIGITAL SIGNAGE + PI (LINE/FLOOR, BINARY, KONE, SEC, QL, HX) – MAIN COP (NO VMS)

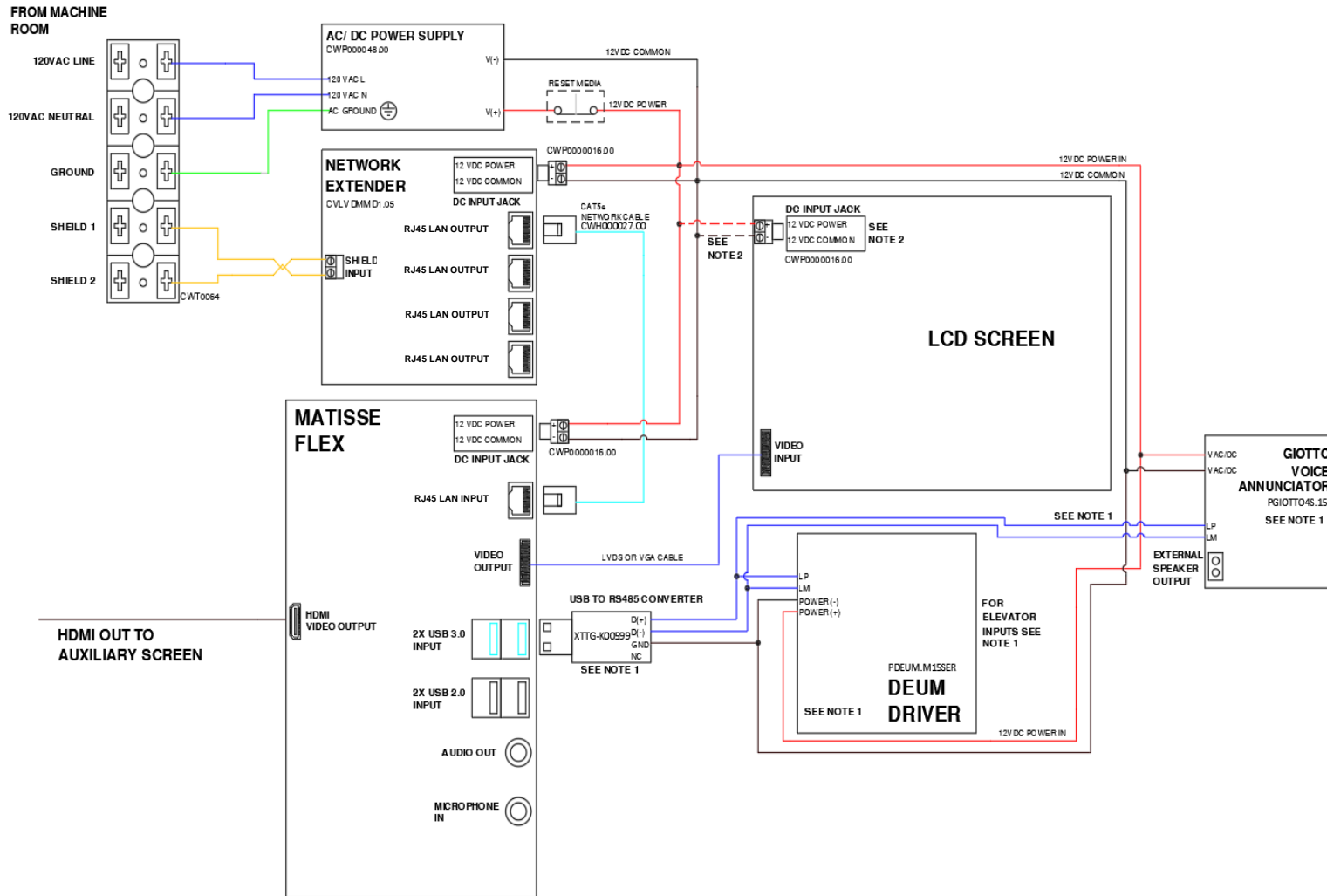

Notes:

NOTE 1: FOR ELEVATOR FLOOR INPUTS, PRIORITY MESSAGES, REFER TO DEUM POSITION INDICATOR ENCODER QUICK GUIDE. FOR SERIAL ELEVATOR INPUTS WITH VOICE ANNUNCIATION USE PDEUM.M1SSER WITH PGIOTTO4S.15 CONNECT THE LP AND LM SIGNALS TO PDEUM15.SER AND TO GIOTTO4S.15

NOTE 2: WHEN CONNECTING THE LCD SCREEN TO MATISSEFLEX VIA VGA CONNECT THE 12V POWER TO THE LCD POWER INPUT USING THE POWER PLUG CWP0000016.00

Voltage: 120 VAC	Signal Format:
Controller:	Code Year:
Drawing Name: Matisse Flex PI/Digital Signage Using Line Floor/Binary With LCD Screen MAIN COP Electrical Wiring Diagram	
Rev: 1	Qty: 1



4 MATISSE FLEX PI - DIGITAL SIGNAGE + PI (LINE/FLOOR, BINARY) - MAIN COP (NO VMS) - DEUM DRIVER IN MACHINE ROOM

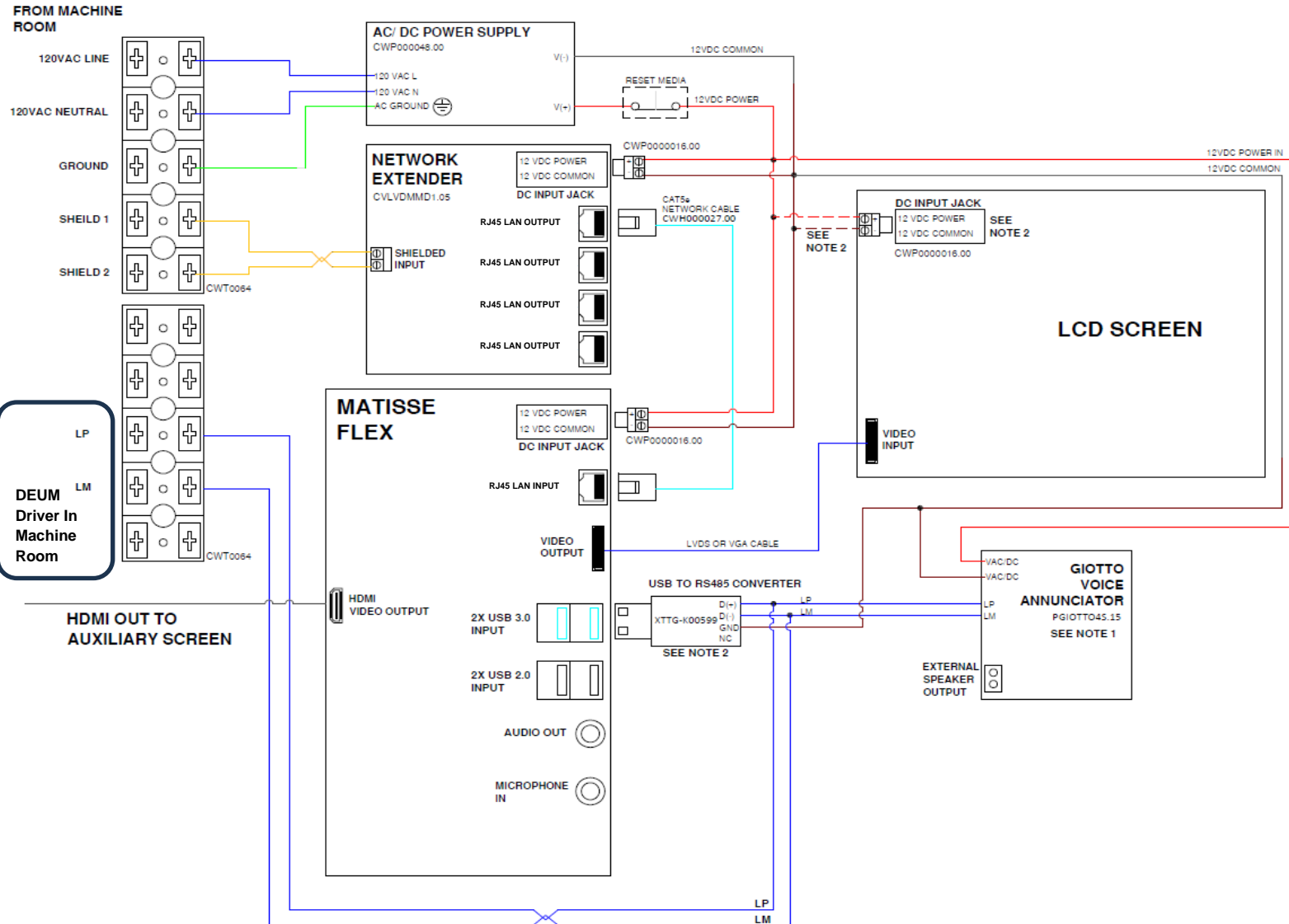

Notes:
NOTE 1: FOR ELEVATOR FLOOR INPUTS, PRIORITY MESSAGES, REFER TO DEUM POSITION INDICATOR ENCODER QUICK GUIDE. FOR SERIAL ELEVATOR INPUTS WITH VOICE ANNUNCIATION USE PDEUM15SER WITH PGIOTTO45.15. CONNECT THE LP AND LM SIGNALS TO PDEUM15SER AND TO GIOTTO45.15
NOTE 2: WHEN CONNECTING THE LCD SCREEN TO MATISSEFLEX VIA VGA CONNECT THE 12V POWER TO THE LCD POWER INPUT USING THE POWER PLUG CWP000016.00

Voltage: 120 VAC	Signal Format:
Controller:	Code Year:
Drawing Name: Matisse Flex PI/Digital Signage Using Line Floor/Binary With DEUM Driver In Machine Room Box MAIN COP Electrical Wiring Diagram	
Rev: 1	Qty: 1



5 MATISSE FLEX - DIGITAL SIGNAGE + PI (CAN PROTOCOL) + VMS – MAIN

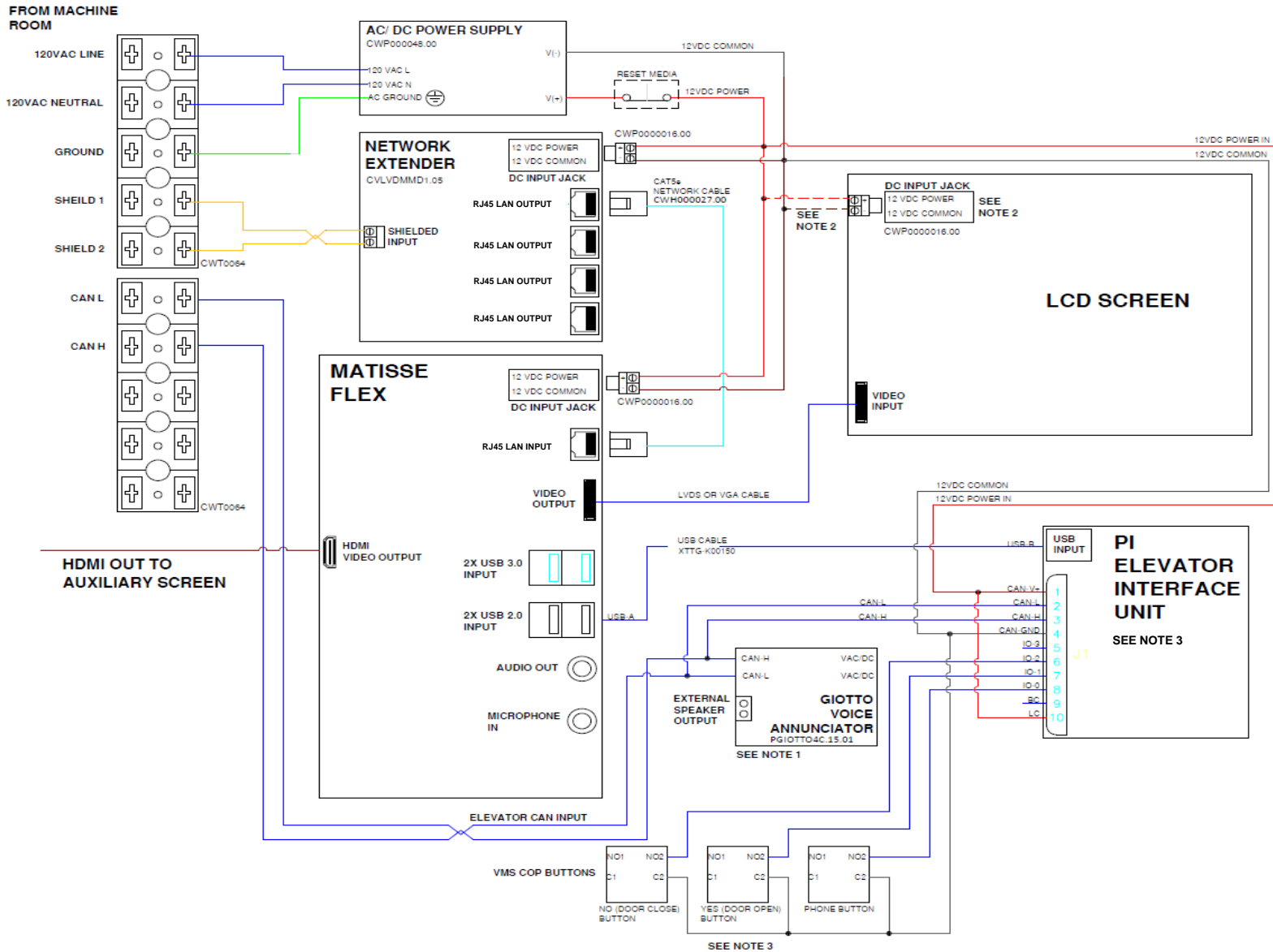

Notes:

NOTE 1: FOR ELEVATOR WITH CAN COMMUNICATION CONNECT ONLY THE EIU (PINTERFACE.00) WITH USB CABLE TO THE MATISSE FLEX. CAN H AND CAN L SIGNALS FROM THE ELEVATOR CONTROLLER ARE CONNECTED BOTH TO THE EIU AND THE VOICE ANNUNCIATOR (PGIOTT04C.15.01).

NOTE 2: WHEN CONNECTING THE LCD SCREEN TO MATISSE FLEX VIA VGA CONNECT THE 12V POWER TO THE LCD POWER INPUT USING THE POWER PLUG CWP000016.00

NOTE 3: FOR THE EIU MAPPING IO-0 IS CONNECTED TO THE PHONE BUTTON, IO-1 IS CONNECTED TO THE YES (DOOR OPEN) BUTTON, IO-2 IS CONNECTED TO THE NO (DOOR CLOSE) BUTTON, FOR THE PROGRAMMING THE EIU HAS TO PROGRAMMED FOR A FLOOR THAT IS NOT IN USE. IO-0 IS PROGRAMMED TO FLOOR 110, IO-1 IS PROGRAMMED TO FLOOR 111, IO-2 IS PROGRAMMED TO FLOOR 112

Voltage: 120 VAC	Signal Format:
Controller:	Code Year:
Drawing Name: Matisse Flex PI/Digital Signage With VMS Using CAN With LCD Screen MAIN COP Electrical Wiring Diagram	
Rev: 1	Qty: 1



6 MATISSE FLEX – DIGITAL SIGNAGE + PI (LINE/FLOOR, BINARY, KONE, SEC, QL, HX) + VMS – MAIN COP

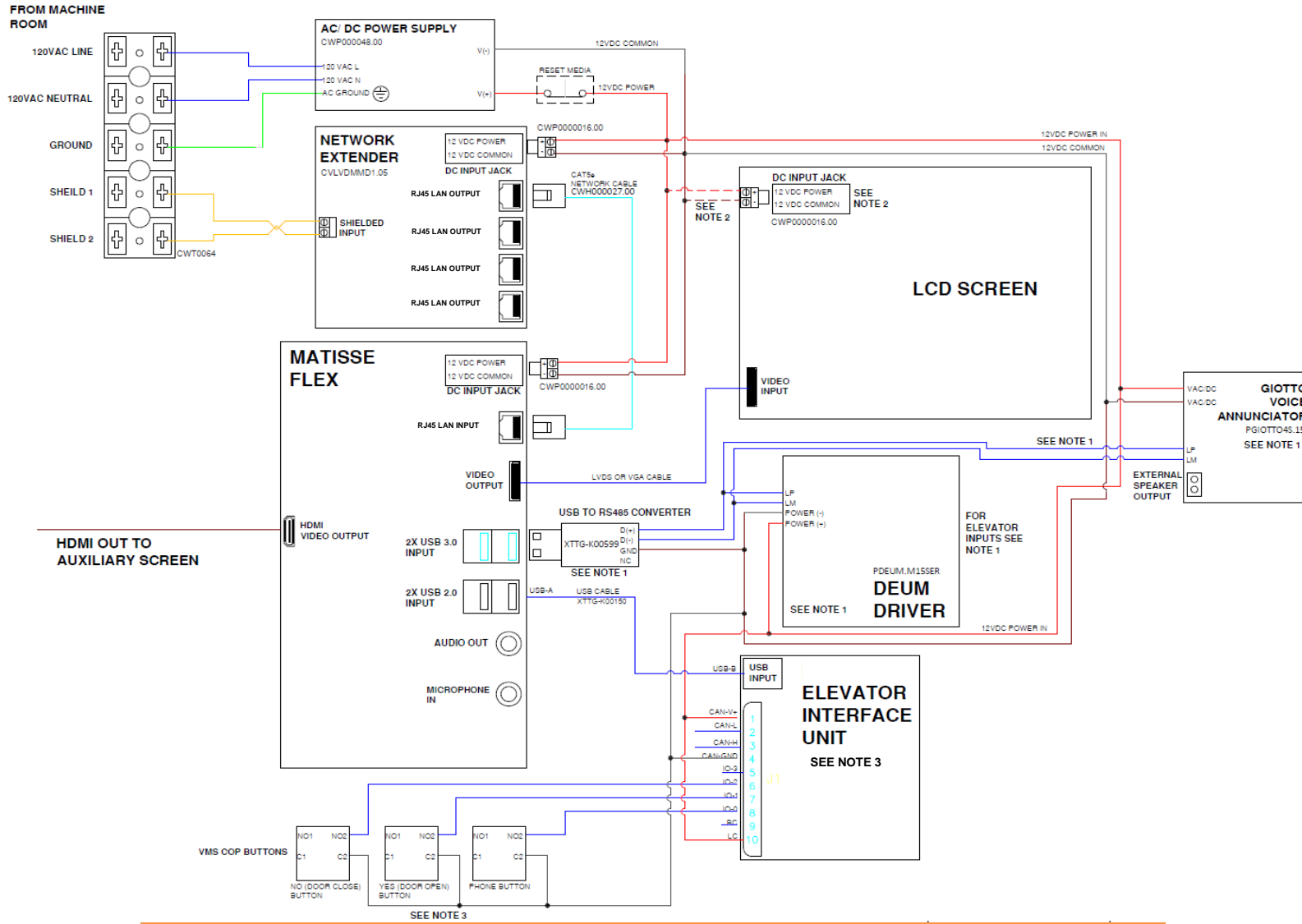

Notes:

NOTE 1: FOR ELEVATOR FLOOR INPUTS, PRIORITY MESSAGES, REFER TO DEUM POSITION INDICATOR ENCODER QUICK GUIDE. FOR SERIAL ELEVATOR INPUTS WITH VOICE ANNUNCIATION USE PDEUM.M15SER WITH PGIOTTO4S.15 CONNECT THE LP AND LM SIGNALS TO PDEUM15.SER AND TO GIOTTO4S.15

NOTE 2: WHEN CONNECTING THE LCD SCREEN TO MATISSEFLEX VIA VGA CONNECT THE 12V POWER TO THE LCD POWER INPUT USING THE POWER PLUG CWP0000016.00

NOTE 3: FOR THE EIU MAPPING IO-0 IS CONNECTED TO THE PHONE BUTTON, IO-1 IS CONNECTED TO THE YES (DOOR OPEN) BUTTON, IO-2 IS CONNECTED TO THE NO (DOOR CLOSE) BUTTON. FOR THE PROGRAMMING THE EIU HAS TO BE PROGRAMMED FOR A FLOOR THAT IS NOT IN USE. IO-0 IS PROGRAMMED TO FLOOR 110, IO-1 IS PROGRAMMED TO FLOOR 111, IO-2 IS PROGRAMMED TO FLOOR 112

Voltage: 120 VAC	Signal Format:
Controller:	Code Year:
Drawing Name: Matisse Flex PI/Digital Signage Using Line Floor/Binary With VMS,LCD Screen MAIN COP Electrical Wiring Diagram	
Rev: 1	Qty: 1



7 MATISSE FLEX PI - DIGITAL SIGNAGE + PI (LINE/FLOOR, BINARY) + VMS - MAIN COP – DEUM DRIVER IN MACHINE ROOM

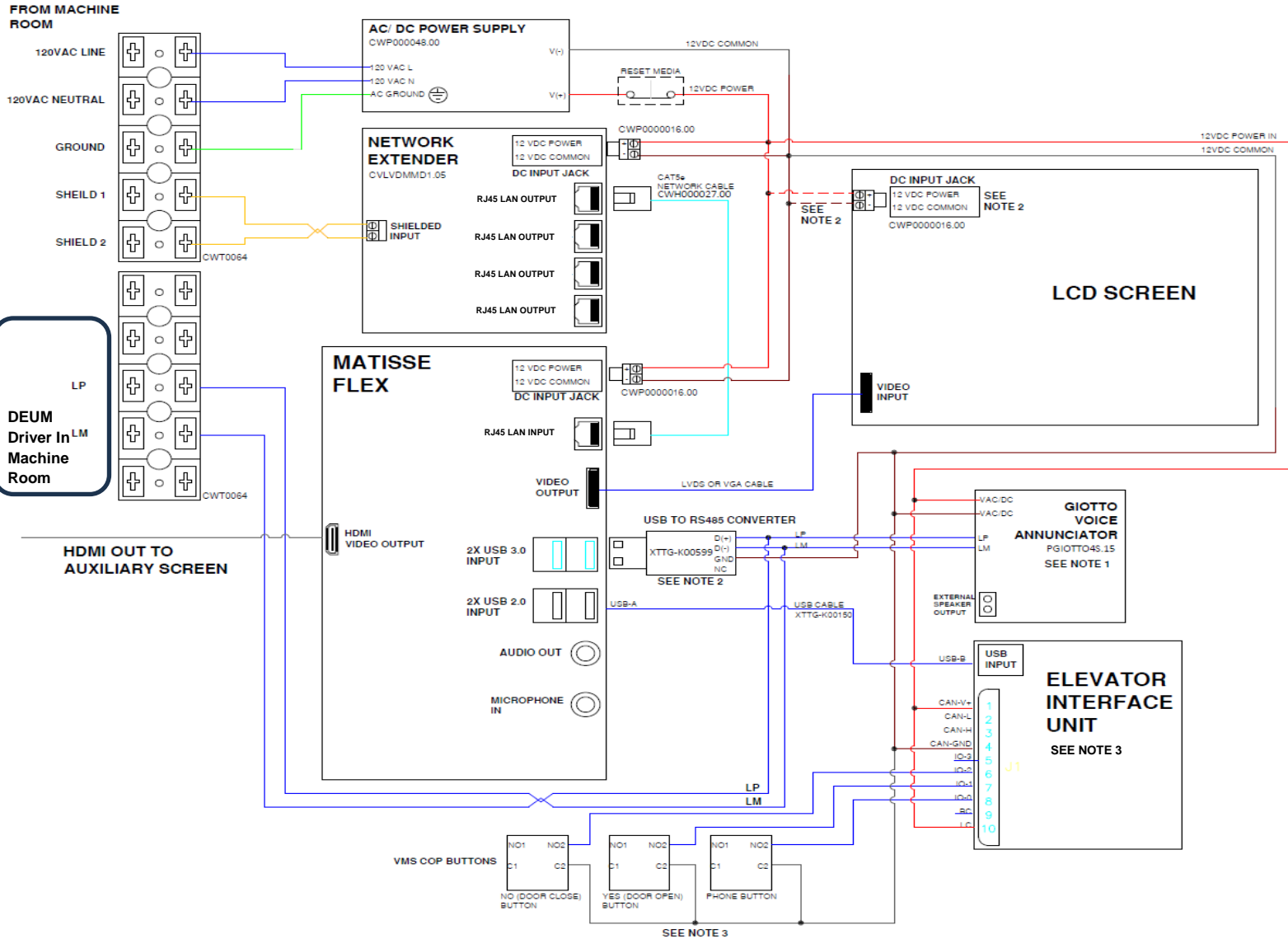

Notes:

NOTE 1: FOR ELEVATOR FLOOR INPUTS, PRIORITY MESSAGES, REFER TO DEUM POSITION INDICATOR ENCODER QUICK GUIDE. FOR SERIAL ELEVATOR INPUTS WITH VOICE ANNUNCIATION USE PDEUM M15SER WITH FGIOTTO4S.15 CONNECT THE LP AND LM SIGNALS TO PDEUM15.SER AND TO GIOTTO4S.15

NOTE 2: WHEN CONNECTING THE LCD SCREEN TO MATISSEFLEX VIA VGA CONNECT THE 12V POWER TO THE LCD POWER INPUT USING THE POWER PLUG CWP000016.00

NOTE 3: FOR THE EIU MAPPING IO-0 IS CONNECTED TO THE PHONE BUTTON, IO-1 IS CONNECTED TO THE YES (DOOR OPEN) BUTTON, IO-2 IS CONNECTED TO THE NO (DOOR CLOSE) BUTTON, FOR THE PROGRAMMING THE EIU HAS TO BE PROGRAMMED FOR A FLOOR THAT IS NOT IN USE. IO-0 IS PROGRAMMED TO FLOOR 110, IO-1 IS PROGRAMMED TO FLOOR 111, IO-2 IS PROGRAMMED TO FLOOR 112

Voltage: 120 VAC	Signal Format:
Controller:	Code Year:

Drawing Name:
Matisse Flex PI/Digital Signage With VMS Using Line/Floor/Binary With DEUM Driver In Machine Room Box
MAIN COP Electrical Wiring Diagram

Rev:	Qty:
1	1



8 MATISSE FLEX PI / DIGITAL SIGNAGE AUX COP ELECTRICAL WIRING DIAGRAM

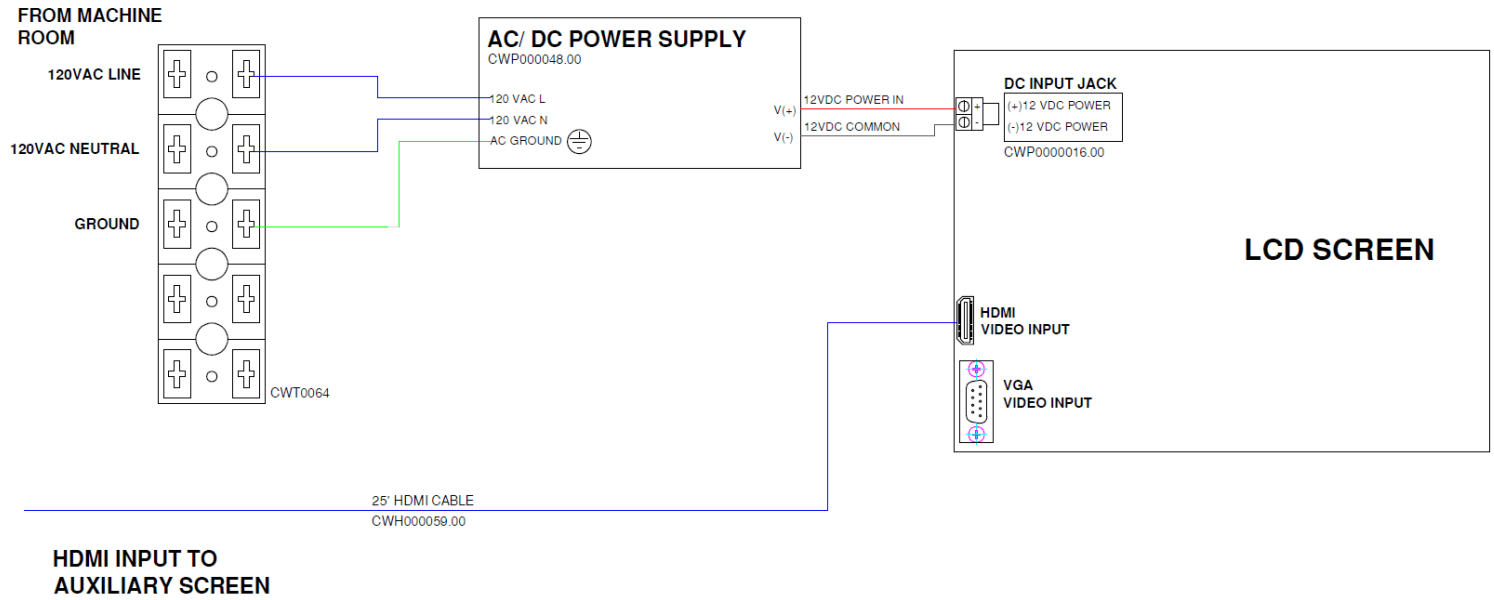

Notes:

Voltage: 120 VAC	Signal Format:		
Controller:	Code Year:		
Drawing Name: Matisse Flex PI/Digital Signage With LCD Screen AUX COP Electrical Wiring Diagram			
		Rev: 1	Qty: 1